

VC-MPT126 - ISOMETRIC VIEW
SCALE: 1"=1'-0"(1:12)

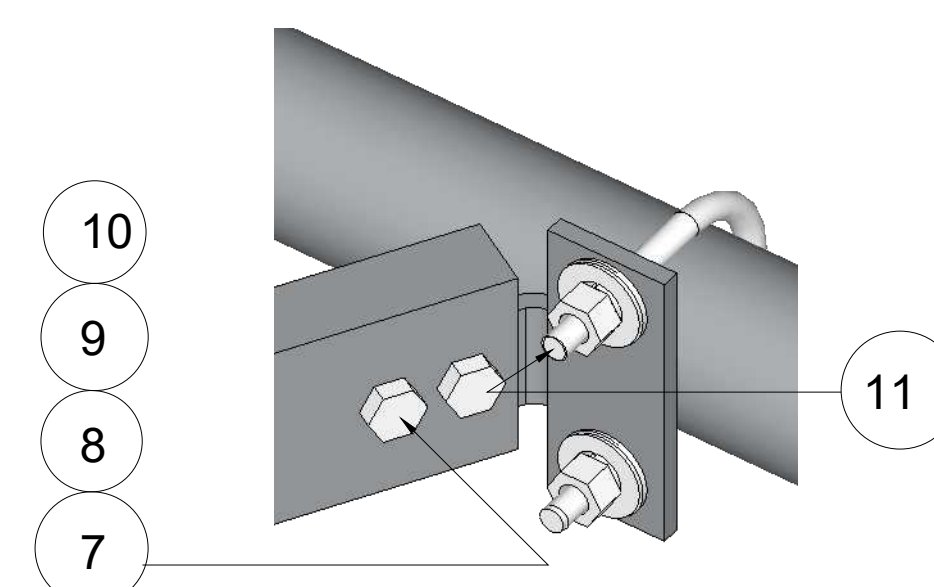

DETAIL-B

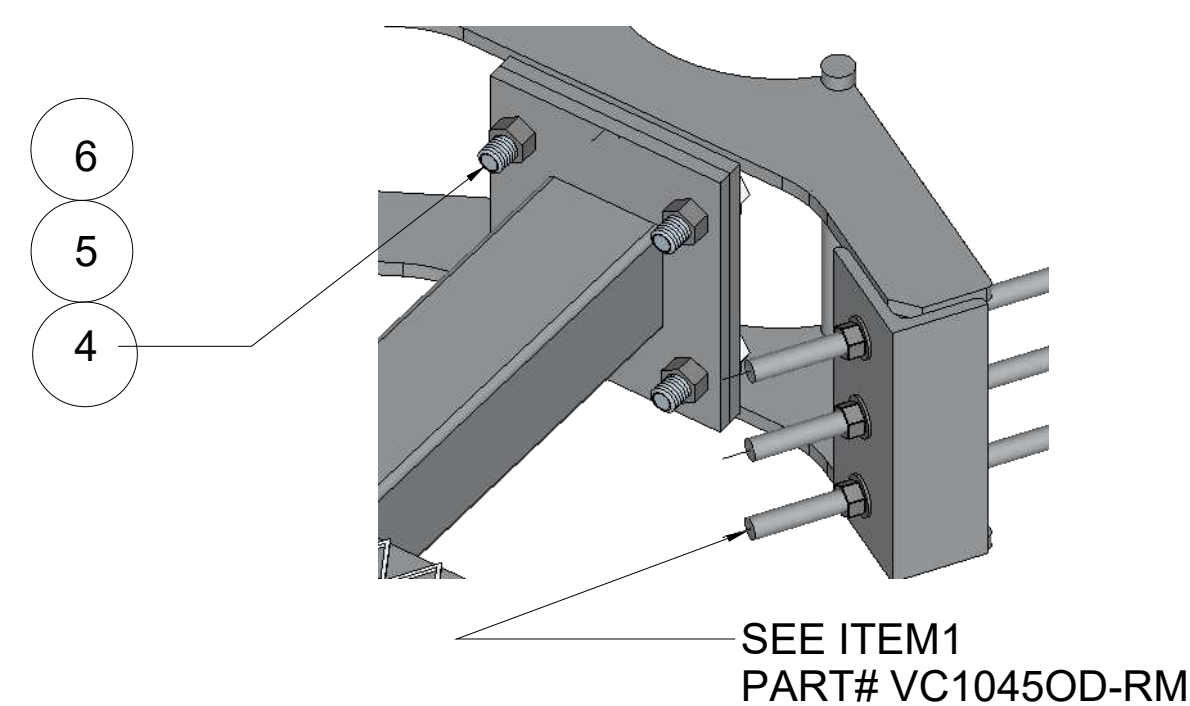

DETAIL-A

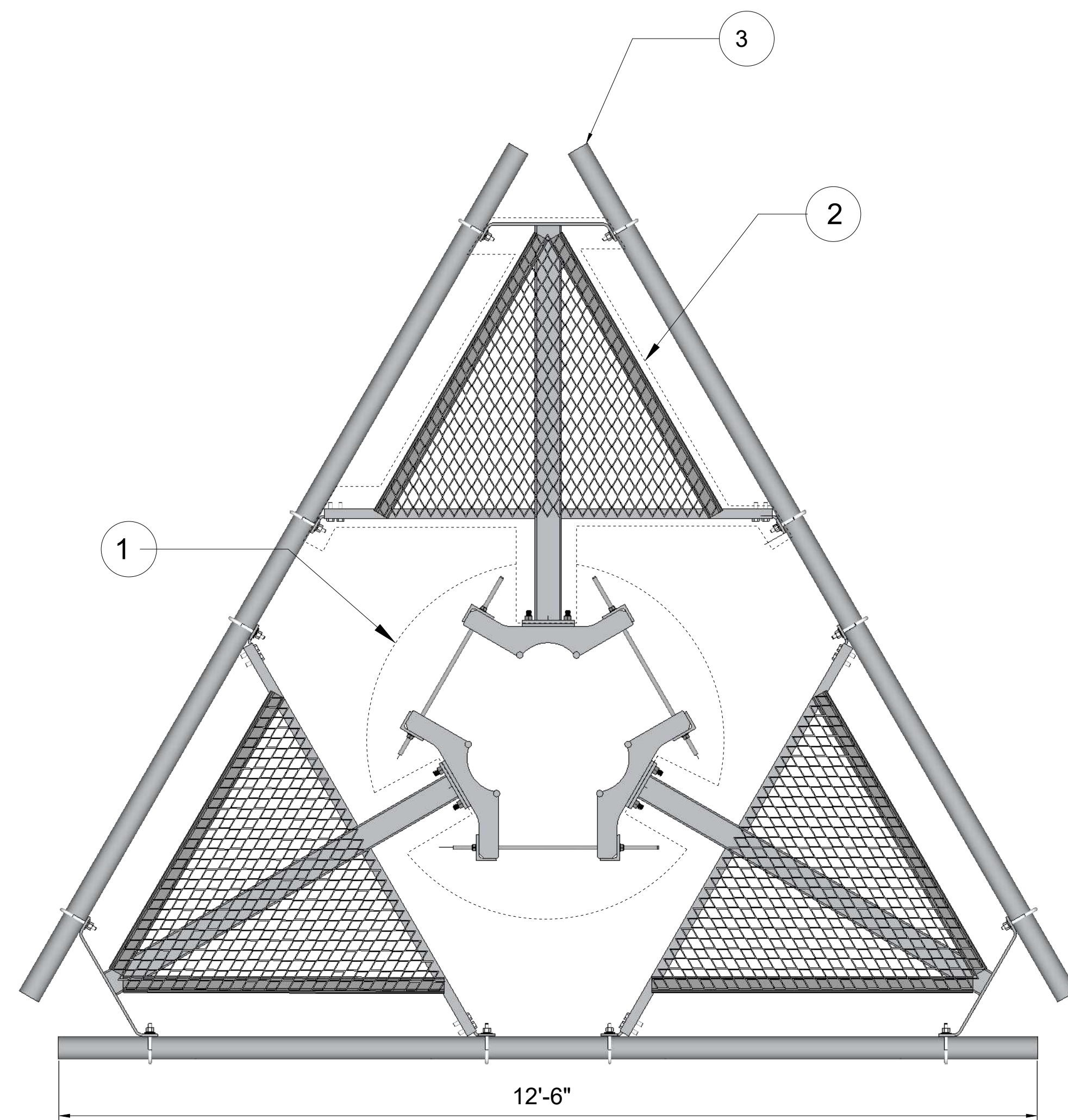

VC-MPT126 - TOP VIEW

SCALE: 1"=1'-0"(1:12)

PARTS LIST

ITEM	QTY.	PART #	DESCRIPTION	LENGTH	UNIT WT.(lb)	TOTAL WT.(lb)
1	3	VC-1045OD-RM	RING MOUNT WELDMENT W/HARDWARE		51.00	152.31
2	3	VC-MTP126-S	LOW PROFILE PLATFORM CORNER		190.23	570.68
3	3	P3	3" PIPE A500 GR.C 0.165" WALL GALVANIZED PIPE	12'-6"	94.95	284.85
4	12	A34HB-3	3/4"-10X3" A325 HEX BOLT (HDG.)		0.71	8.52
5	12	A34LW	3/4" HDG. LOCKWASHER		0.01	0.24
6	12	A34NUT	3/4" HDG. HEX NUT		0.07	0.84
7	12	B12	1/2"-13-X2" A325 HEX BOLT (HDG.)		0.35	4.20
8	12	B12FW	1/2" HDG FLATWASHER		0.03	0.82
9	12	B12LW	1/2" HDG LOCKWASHER		0.01	0.33
10	12	B12NUT	1/2" HDG HEAVY HEX NUT		0.07	0.84
11	12	X-UB1306	1/2"X3-5/8"X6"X3 U-BOLT ASSEMBLY (HDG.)		0.26	3.12

TOLERANCE NOTES:

TOLERANCE ON DIMENSIONS, UNLESS OTHERWISE NOTED ARE:
 SAWED, SHEARED AND GAS CUT EDGES (+ OR - 0.030")
 DRILLED AND GAS CUT HOLES (+ OR - 0.030") - NO CONNING OF HOLES
 LASER CUT EDGES AND HOLES (+ OR - 0.030") - NO CONNING OF HOLES
 BENDS ARE +OR - 1/2" DEGREE
 ALL OTHER MACHINING (+ OR - 0.030")
 ALL OTHER ASSEMBLY (+ OR - 0.030")

DATE	DWG USAGE:	DWG #:	DRAWN BY:
04/19/22	VANCOMM CUSTOMER DRAWING	VC-MPT126	PF
SCALE	DWG DESCRIPTION:	PART #:	CHECKED BY:
AS NOTED	VANCOMM MONOPOLE TRIANGULAR PLATFORM	AS NOTED	PAGE
			1 of 3

PROPRIETARY NOTE:

THIS DOCUMENT AND THE INFORMATION IT CONTAINS IS PROPRIETARY AND CONFIDENTIAL TO VANCOMM LLC. IT HAS BEEN PROVIDED ONLY FOR YOUR INTERNAL USE IN CONSIDERING A PURCHASE FROM VANCOMM LLC. NEITHER THIS DOCUMENT NOR ANY PORTION THEREOF MAY BE RELEASED OR DISCLOSED TO ANY THIRD PARTY WITHOUT PRIOR CONSENT FROM VANCOMM LLC. PLEASE DESTROY ALL COPIES OF THIS DOCUMENT IF YOU CANNOT ACCEPT THIS PROPRIETARY RESTRICTION. DOCUMENT COPYRIGHT@2021, VANCOMM LLC.



The Original Mount
Build Not Destroy

2512 Route 73 North, Cinnaminson, NJ 08077